

## Description

ROBINHOOD 60CM WALL CANOPY DC MOTOR

RWE3CL6SSDC (Stainless Steel); RWE3CL6MBDC (Matte Black)



RWE3CL6SSDC



RWE3CL6MBDC

## Key Features

### Motor Type

DC Motor

### Max Motor Performance

700 m<sup>3</sup>/hr

### Power Levels

3

### Control Type

Backlit Buttons

### Light

2 x 1.5W LED

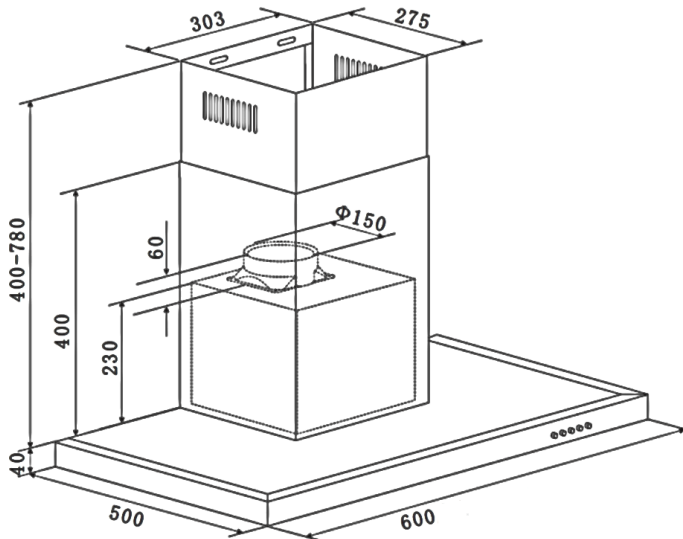

Dated 20/05/2022

## Specifications

<b>Voltage</b>	220~240v
<b>Frequency</b>	50~60Hz
<b>Motor Type/ Power</b>	DC motor/ 81W
<b>Energy Efficiency Index (EEI)</b>	A+
<b>Max Motor Performance</b>	700 m <sup>3</sup> /hr
<b>Power Levels</b>	3
<b>Control Type</b>	Backlit buttons
<b>Light/ Colour Temperature</b>	2 x 1.5W LED/ 6500K
<b>Filter</b>	2 x S/S decorative aluminium filters
<b>Recirculating Mode</b>	Yes, optional charcoal filter RHCF115
<b>Ducting Outlet</b>	Ø150mm
<b>Power Cord Length</b>	1.8m
<b>Optional Extension Flue Kit</b>	RWE3CL6SSDC: 2611(1420mm); 2612(2100mm) RWE3CL6MBDC: 2611MB(1420mm)
<b>Product Dimensions (WxDxH)</b>	600 x 500 x (440-820)mm
<b>Carton Dimensions (WxDxH)</b>	660 x 370 x 570mm
<b>Gross/ Net Weight</b>	13.7/10.6Kg

Air Flow & Noise Level*		
Power Level	Air Flow (m <sup>3</sup> /hr) (IEC 61591)	Noise Level (dB) (IEC 60704-2-13)
1	205	31
2	414	46
3	615	53

\*Air Flow & Noise Level testing is conducted in a controlled lab environment as per the IEC standards.