

Description

ROBINHOOD POWERPACK STAINLESS STEEL REVERSIBLE MOTOR
RPI3CL52SS (52cm); RPI3CL82SS (82cm)

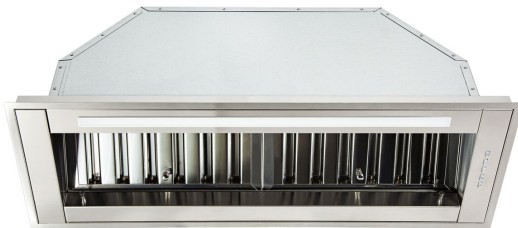

RPI3CL52SS



RPI3CL82SS

Key Features

Max Motor Performance
 900 m³/hr

Power Levels
 3 + Intensive

Control Type
 Backlit Buttons

Lighting
 LED Strip

Venting Type
 Reversible motor.

Can be ducted either from the top or rear

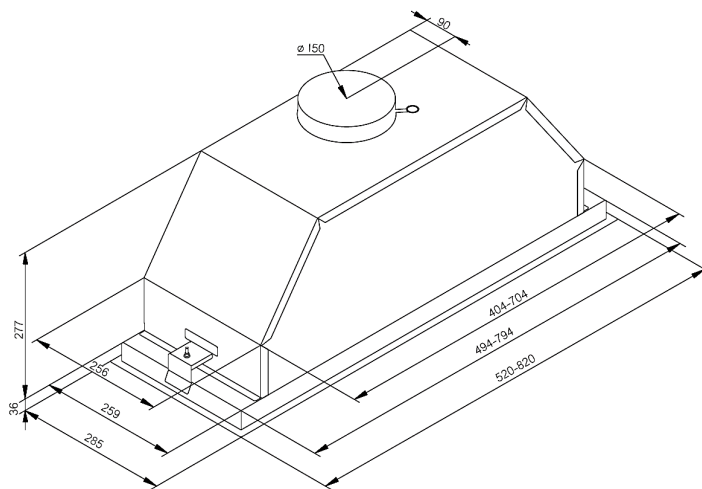

Dated 25/05/2022

Specifications

Voltage/ Frequency	220~240V/ 50-60Hz
Motor Power	240W
Max Motor Performance	900 m ³ /hr
Max Efficiency Pressure	590 Pa
Control Type	Backlit buttons
Power Levels	3 + Intensive
Filter	2 x Baffle filters (20mm thickness)
Ducting Outlet	Ø150mm
Power Cord Length	1.5M

	RPI3CL52SS	RPI3CL82SS
Lighting	2W LED strip	3W LED strip
Product Dimensions (WxDxH)	520 x 285 x 313mm	820 x 285 x 313mm
Packaging Dimensions (WxDxH)	600 x 400 x 380mm	1000 x 400 x 380mm
Cut Out Size (WxD)	503 x 265mm	803 x 265mm
Net/Gross Weight	9/11.8Kg	12/16Kg

Air Flow & Noise Level*		
Power Level	Air Flow (m³/hr) (IEC 61591)	Noise Level (dB) (IEC 60704-2-13)
1	303	40
2	442	50
3	610	57
Intensive	752	61

*Air Flow & Noise Level testing is conducted in a controlled lab environment as per the IEC standards.