

Description

ROBINHOOD POWERPACK 52CM STAINLESS STEEL/ MATTE BLACK
RPC3CL52SS/MB



Key Features

Motor Type & Max Motor Performance

DC Motor & 700m³/hr

Power Level

3

Light

2 x 1.5W LED

Filter

1 x S/S decorative Aluminum filter

Additional Face Plate

1 x Matte Black face plate included

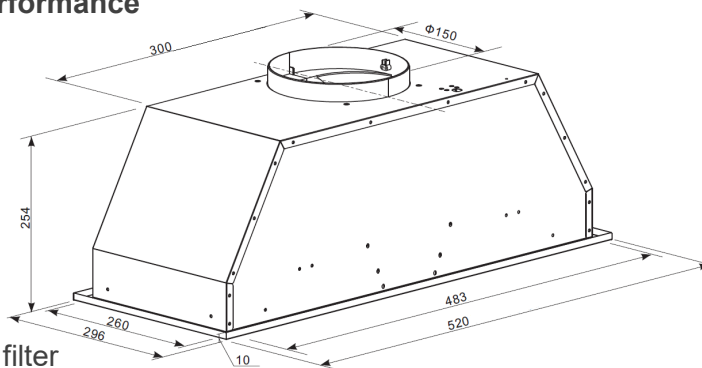

Dated 20/05/2022

Specifications

Voltage	220~240v
Frequency	50~60Hz
Motor Power	80W
Max Motor Performance	700 m ³ /hr
Lighting	2 x 1.5W LED
Control Type	Backlit buttons
Power Levels	3
Filter	1 x S/S decorative Aluminum filter
Installation Type	Ducted (recommended) or recirculated with optional charcoal filter
Ducting Outlet Diameter	Ø150mm
Chimney	No chimney
Product Dimensions (WxDxH)	520x296x254mm
Packaging Dimensions (WxDxH)	570x360x365mm
Cut Out Size (WxD)	483x260mm
Gross/Net Weight	7.0/6.0Kg

Power Level	Air Flow & Noise Level*	
	Air Flow (m ³ /hr) (IEC 61591)	Noise Level (dB) (IEC 60704-2-13)
1	205	31
2	414	46
3	615	53

*Air Flow & Noise Level testing is conducted in a controlled lab environment as per the IEC standards.