

Serie | 6, Built-in freezer, 177.2 x 55.8 cm
GIN81AC30A



The NoFrost freezer with electronic temperature control: set the target temperature precisely and easily.

- **VarioZone:** more flexibility due to variable-use glass shelves and drawers in the freezer compartment
- **NoFrost:** thanks to perfect protection from ice formation - that saves time and effort.
- **BigBox frozen food drawer:** for stacking storage containers or for large frozen food items.

Technical Data

Thermometer freeze section :	Digital
Light :	No
Product category :	Upright freezer
Built-in / Free-standing :	Built-in
Door panel options :	Not possible
Frost free system :	Fridge and freezer
Height of the product (mm) :	1772
Width of the appliance :	558
Depth of the product :	545
Dimensions of the packed product (HxWxD) (mm) :	1840 x 640 x 620
Net weight (kg) :	64.816
Gross weight (kg) :	70.0
Connection Rating (W) :	120
Current (A) :	10
Frequency (Hz) :	50
Approval certificates :	CE, VDE
Length electrical supply cord (cm) :	230
Door hinge :	Left reversible
Storage Period in Event of Power Failure (h) :	22
Warning signal / malfunction :	visual and audible
Lockable door :	No
Number of drawers/baskets (Stck) :	5
Number of freezing flaps (Stck) :	2
EAN code :	4242005210657
Brand :	Bosch
Product name / Commercial code :	GIN81AC30A
Product category :	Upright freezer
Energy consumption annual (kWh/annum) - NEW (2010/30/EC) :	243.00
Freezer Net capacity (l) - NEW (2010/30/EC) :	221
Freezing capacity (kg/24h) - NEW (2010/30/EC) :	20
Climate class :	SN-T
Noise level (dB) :	36
Installation typology :	Full-integrated



4 242005 210657

Serie | 6, Built-in freezer, 177.2 x 55.8 cm GIN81AC30A

The NoFrost freezer with electronic temperature control: set the target temperature precisely and easily.

- Frost free, Built-in upright-freezer (> 90 cm height)
- Integrated, Flat hinge
- Reversible door hinging

Convenience & Safety

- Frost free Multi Airflow system
- Independent controls for fridge and freezer
- 2 hinged freezer compartments with transparent front
- 5 transparent freezer drawers, incl.2

Energy rating

- 3 Star Energy Rating : 260 kwh per year

Volume

- Gross capacity, total: 235 l
- Net freezer capacity 221 litres

Technical Information

- 1 X 15wt lighting in fridge
- Rated Voltage 220 - 240 V

Dimensions

- H 177.2 cm x W 55.8 cm x D 54.5 cm
- Niche Dimension H X W x D: 177.5 cm x 56 cm x 55 cm
- Width with opened door (90°): 56 cm
- Appliance width: 55.8 cm

Accessories

- 2 x cold accumulator, 1 x ice cube tray
- 235 litres total gross volume

Freezer Section

- Automatic switch off
- Flat hinge
- 3 Star Rating Energy Efficiency
- Net fridge capacity total: 0 l
- Net capacity, total: 221 l

**Serie | 6, Built-in freezer, 177.2 x 55.8 cm
GIN81AC30A**

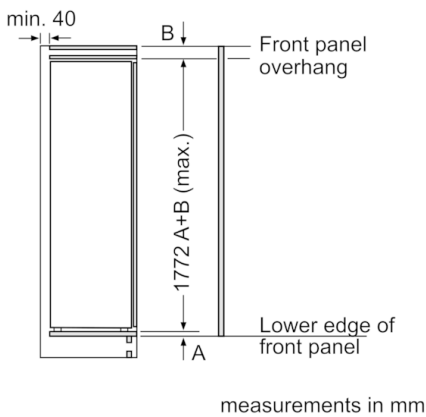
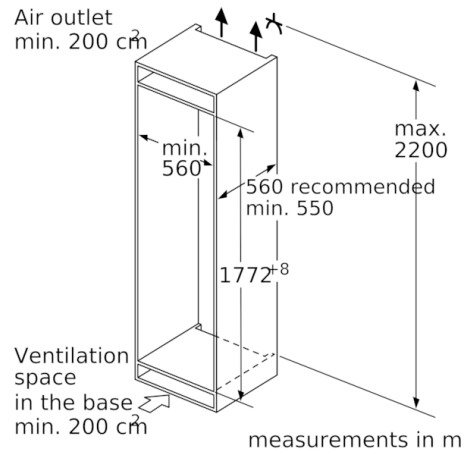
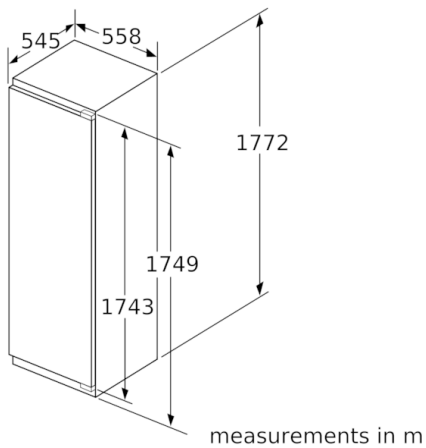

Maximal permissible weight of the unit fronts

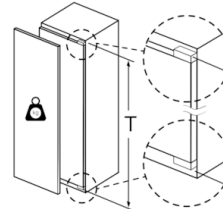

Fitted kitchen unit doors that exceed the permissible weight may cause damage and result in functional impairment of the hinges.

T: Includes height of appliance door	undamped hinge, Door in kg:	damped hinge, Door in kg:
Hinges in mm: 1500-1750	22	22

measurements in mm
Recommended gap dimensions for flat hinges

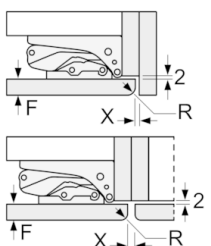

F	R	X
16-19	0-3	2.5
20	0-1	3
	2-3	2.5
21	0-1	3
	2-3	2.5
22	0	4
	1	3.5
	2-3	3

The gap dimensions recommended in the table must be adhered to in order to ensure that appliance doors do not collide with anything when they are opened, and to avoid causing damage to kitchen units.

Maximal permissible weight of the unit fronts

Fitted unit fronts that exceed the permissible weight may cause damage and result in functional impairment of the hinges

Δ Weight
A: Appliance door height including hinges in mm
B: Undamped hinge, unit front in kg
C: Damped hinge, unit front in kg

A	B	C
1500-1750	22	22
720-1400	19	19
A1	15	19
A2	15	19